



Poster Instructions for Paper Posters

Poster Session	Presentation Day	Presence at Poster	Poster Mounting Time	Poster Removal Time
1	Wednesday, 06 May 2026	While Poster Viewing	Wednesday, 06 May 2025, 07.30 – 08.30	Wednesday, 06 May 2025, 19.45 – 20.15
2	Thursday, 07 May 2026	While Poster Viewing	Thursday, 07 May 2025, 08.00 – 09.00	Friday, 08 May 2025, 10.30 – 13.00
Poster numbers P1 – P480 on 6th of May 2025 Poster numbers P501 – P980 on 7th of May 2025				

Posters that are not dismantled after the indicated time will be disposed of.

- For information the poster panel is 97cm x 122cm hence to ensure the paper poster to fit in the frame it is highly recommended that you print your poster smaller

- Max. poster measurements: **VERTICAL PRESENTATION**
Max Width: 97 cm
Max Height: 122 cm

- We suggest you design your poster layout as follows:
 - Title, author, address (on the upper edge, across the width of the whole poster)
 - Introduction and Purpose
 - Methods
 - Results
 - Conclusions
 - Disclosure**

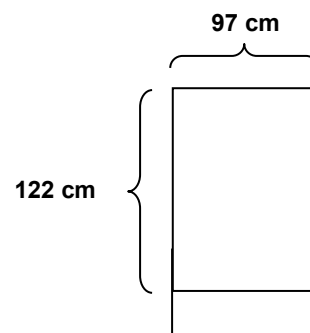

A layout example can be found [here](#) or download the ePoster template from our website

- Disclosure** of conflict of interest (e.g., grant support, consultancy, membership on advisory councils, speaker's bureau) and source of funding **is mandatory**. Please prepare **for each listed author** a one sentence statement to this effect.
- The title should be emphasised by the use of a bold type face. This writing should be easily readable at a distance of 2 – 3 meters. The text can be broken up by the inclusion of drawings, charts and photos.
- To promote your work, you may like to bring handouts for distribution.
- It is recommended that you stand by your poster to answer any questions from interested delegates.
- Poster numbers will be provided and fixed at each poster wall. Your poster number can be found in the Notification letter, as well as on the conference website <https://eso-conference.org/> under "Scientific Programme". Material to affix the posters will be provided.
- Please strictly adhere to the mounting and removal times. If the poster has not been removed by the end of the allocated removal time, it will be disposed of by conference staff.

Should you have any questions, please do not hesitate to contact the Conference Secretariat in Basel, Switzerland: Phone: +41 61 686 77 99 - E-mail: ESOC.abstracts@congrex.com